

TYPICAL



GC6717MD2 DIRECT DRIVE LOCKSTITCH SEWING MACHINE WITH THREAD TRIMMER AND EDGE CUTTER

INSTRUCTION BOOK

※NOTE

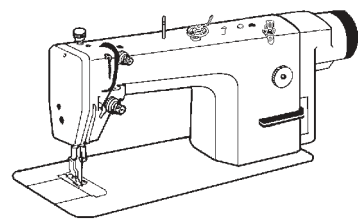

The sewing machine should always be lubricated and the oil supply replenished before it is used for the first time, and also replenished if it is used for the first time, and also after long periods of non-use use only the lubricating oil our company. Then lift the presser foot and run the machine at a low speed of 3000 spm to check oil distributing condition through oil check window. When lubricating is normal, keep the machine run in at this speed for 30 minutes, then increase the running speed gradually. After one month run-in operation, the machine can be run at the max speed under normal working condition.

2. ROTATING HOOK OIL AMOUNT ADJUSTMENT

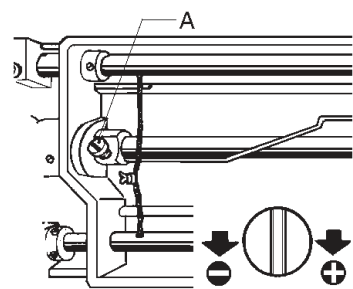

Adjust the oil amount of the rotating hook by turning the oil amount adjusting screw (A). Turn the screw (A) clockwise (in the "+" direction) to increase the oil amount; turn it counter-clockwise (in the "-" direction) to decrease the oil amount.

4. NEEDLE INSTALLATION

Turning the balance wheel to lift the needle bar to the upper end of its stroke. Loosen the needle clamp screw while keeping the long groove of the needle leftward, fully insert the needle shank up to the bottom of the needle socket, then tighten the needle clamp screw.

Note: please take the drive in our motor cover accessory bag to operate.

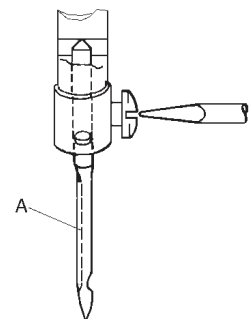

5. CONNECTION OF THE CLUTCH LEVER WITH THE PEDAL

(1) Install speed governor A, link speed governor A and pedal B with tie bar, keep tie bar C vertical.
(2) The optimum tilt angle of pedal is approximately 15 deg.

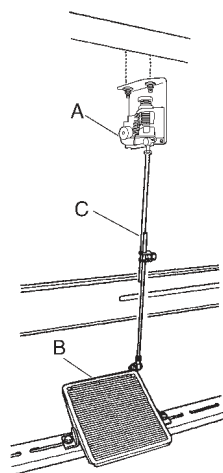

6. ADJUST THE OPENING TIME OF THE TENSION DISCS

Within the presser foot lift range, the opening time of the tension discs can be adjusted as follows:

(1) Remove the rubber plug from the back of the arm and Loosen the screw (A) of the knee lift level (left)
(2) Move the tension releasing cam (D) leftward for earlier opening or rightward for later opening. It will facilitate the adjustment if putting a lifting high block under the presser foot lift.

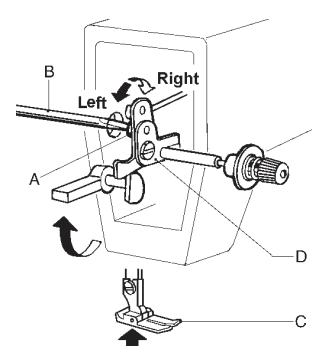

7. THREADING

To thread the needle thread, raise the needle bar to the upper end of its stroke, lead the thread from the spool and perform.

To draw the bobbin thread, hold the end of the needle thread and turn the balance wheel to lower the needle bar and then lift it to its highest position. Pull the ends of needle thread and bobbin thread forward under presser foot.

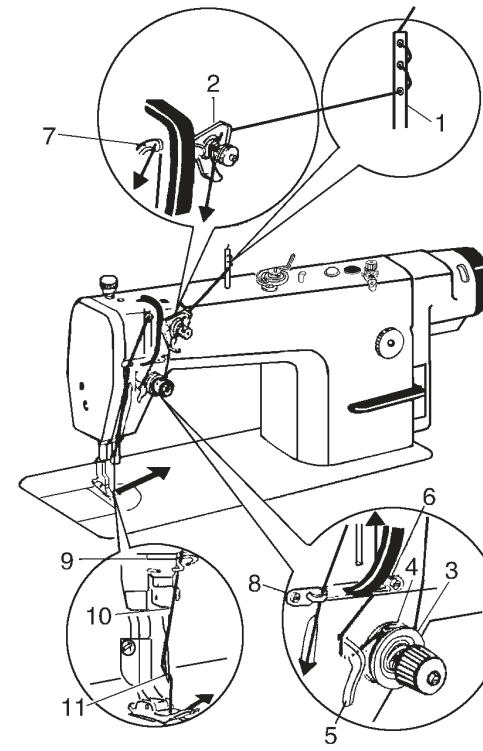

8. WINDING THE LOWER THREAD

Turn on the power switch. Place the bobbin (A) onto the bobbin winder shaft (B). Wind the thread several times around the bobbin (A) in the direction indicated by the arrow. Push the bobbin presser arm (C) toward the bobbin (A). Raise the presser foot with the lifting lever. Depress the treadle. Lower thread winding will then start. Once winding of the lower thread is completed, the bobbin presser arm (C) will return automatically. After the thread has been wound on, remove the bobbin and cut the thread with the knife (D).

NOTE:

- Loosen the screw (E) and move the bobbin presser (C) to adjust the amount of thread wound onto the bobbin.
- The amount of thread wound onto the bobbin should be a maximum of 80% of the bobbin capacity.

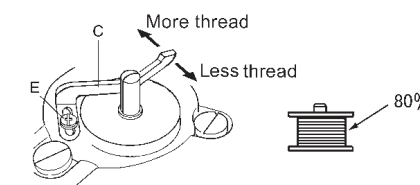
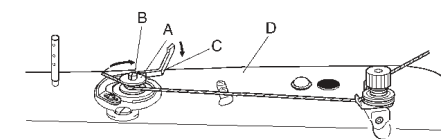

9. ADJUST THE PRESSURE OF PRESSER FOOT

Pressure of the presser foot is adjusted in accordance with thickness of materials to be sewn.

First loosen the lock nut (A), for heavy materials, turn the pressure regulating thumb screw as shown in Fig. (a) to increase the pressure, while for light materials, turn the pressure regulating thumb screw as shown in Fig. (b) to decrease the pressure, then tighten the lock nut (A).

The pressure of the presser foot is recommended to be less as long as normal feeding is ensured.

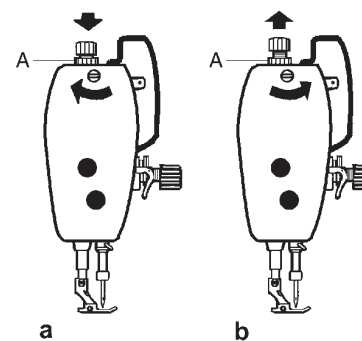

10. THREAD TENSION ADJUSTMENT

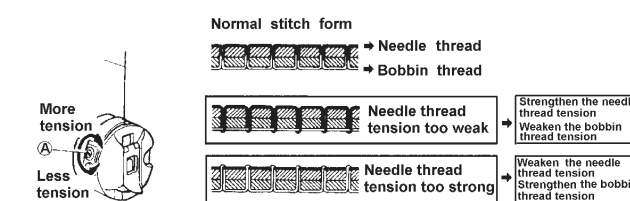

Thread tension should be determined in accordance with the stitch obtained by adjusting the tension of the bobbin thread and needle thread.

The tension of the bobbin thread: to be adjusted by turning the tension regulating screw of the bobbin case. After adjusting, insert the bobbin into the bobbin case and hold the end of the thread from the bobbin case to hang the bobbin case. If the bobbin case falls slowly and evenly, the proper tension of the bobbin thread is obtained.

The tension of needle thread: to be adjusted by turning the thumb nut.

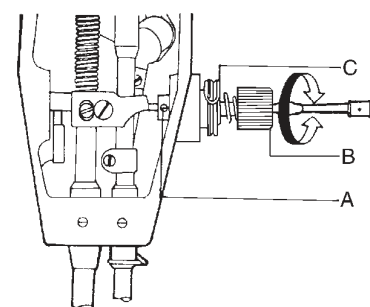

The stroke of the thread take-up spring runs from 6mm to 10mm, when sewing very thin fabrics, reduce the thread take-up spring tension and increase the thread take-up spring stroke, where as increase the thread take-up spring tension and reduce the thread take-up stroke when sewing very thick fabrics.

Adjusting the thread take-up spring tension: First loosen the set screw (A), Turn the tension stud (B) counter-clockwise to decrease the tension of the thread take-up spring (C) to zero. Then turn the tension stud (B) clockwise till the spring (C) comes to the notch of the tension regulating bushing, and again turn the tension stud (B) halfway back (counter clockwise). After the adjustment, tighten the set screw (A).

Adjusting the thread take-up spring stroke: loosen the set screw (B) turn the stud (C) clockwise to increase the stroke or turn stud (C) counter-clockwise to decrease the stroke after the adjustment. Tighten the set screw (B).

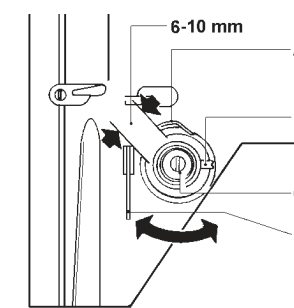

11. ADJUST THE SYNCHRONIZATION OF THE NEEDLE WITH ROTATING HOOK

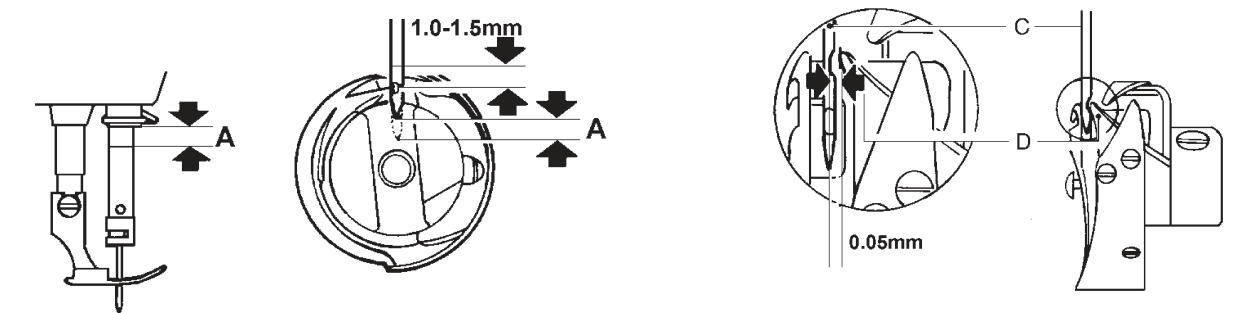

When lifting the needle bar from its lowest position of the stroke to the distance A, the hook point D of the bobbin should align with the center line of the needle and be 1.0-1.5 mm above upper end of the needle eye.

The clearance between the bottom of the needle notch and the hook tip should be 0.05 mm.

12. ADJUSTMENT OF STITCH LENGTH AND REVERSE FEEDING

The stitch length can be adjusted by turning the dial knob (A). The figures on the face (B) of the dial show the stitch length in mm. The reverse feed level must be depressed by another hand while adjusting the stitch length (B). The reverse feeding start when the reverse feed lever (B) is depressed, the machine will feed forward again if the reverse feed level is released.

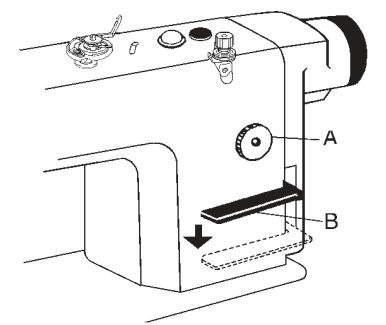

13. ADJUSTING THE POSITION OF FEED DOG AND NEEDLE

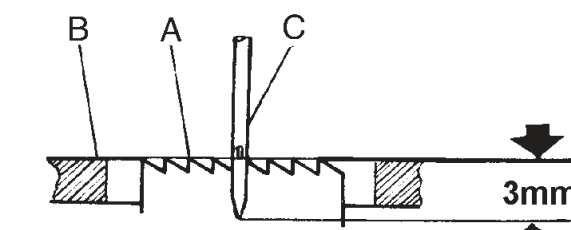

Turn the balance wheel, and lower Feed Dog (A). When the top of the feed dog is flush with needle Plate Surface (B), Needle Point (C) should be 3mm below the needle plate surface.

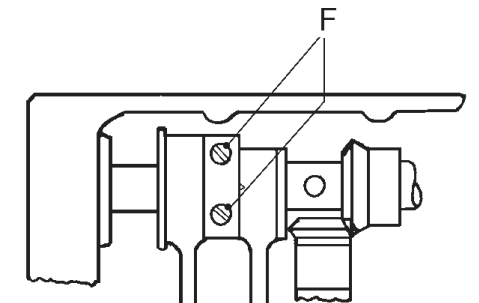

Loosen eccentric wheel screw, turn eccentric wheel and balance wheel separately to adjust the position of needle and feed dog. Then tighten the screw.

14. STITCH LENGTH ERROR ADJUSTMENT

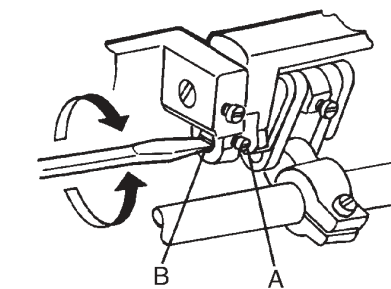

Loosen screw (A) to adjust the stitch length adjusting cam (B). Turn it rightward to narrow the stitch length as forward sewing, and widen it as reverse sewing; turn it leftward to widen the stitch length as forward sewing, and narrow it as reverse sewing.

15. FEED DOG HORI ONTALLY ADJUSTMENT

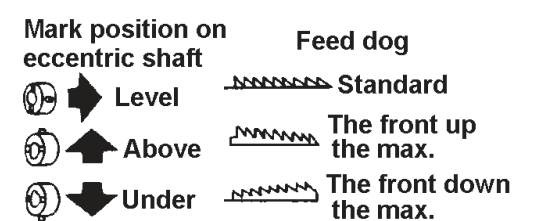

Heighten the front of feed dog to prevent fabric from wrinkling, lower the front of feed dog to prevent fabric from deflection, breaking of hook thread.

16. POSITION OF THE FIXED KNIFE AND LEFT KNIFE POINT

(1) The standard position is shown in the figure.
(2) If the size is larger than the standard, the knife will cut the 3 threads in the meantime or draw the thread out of the needle eye; if smaller, will cause cutting damage, so make sure to avoid that.

(3) As things mentioned above occur, adjustment is done by setting the fixed knife support or the fixed knife (B).

A—the blade B—Fixed knife C—the knife (left)

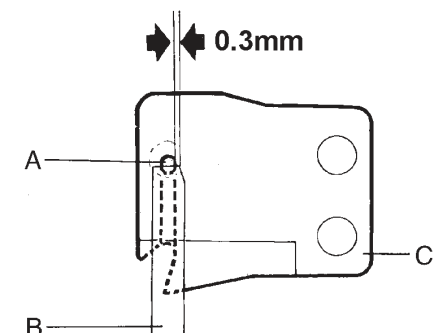

17.POSITION OF THE CUTTER DRIVING SHAFT

- (1)The Standard position is shown in the figure.
- (2)When assemble it,Cutter Driving Shaft (G) should be first put in Cutter Driving Crank (A).
- (3)Set Thread Cutting Cam Crank 1(D) on the cutter driving shaft with reference to the standard position.
- (4)Set Stopper (F), make sure that there is no clearance between parts around the cutter driving shaft, and rotate steadily.

- A—knife driving crank
- B—spring end cover
- C—spring
- D—thread cutting cam crank 1
- E—thread cutting cam crank 2
- F—stopper
- G—knife driving shaft

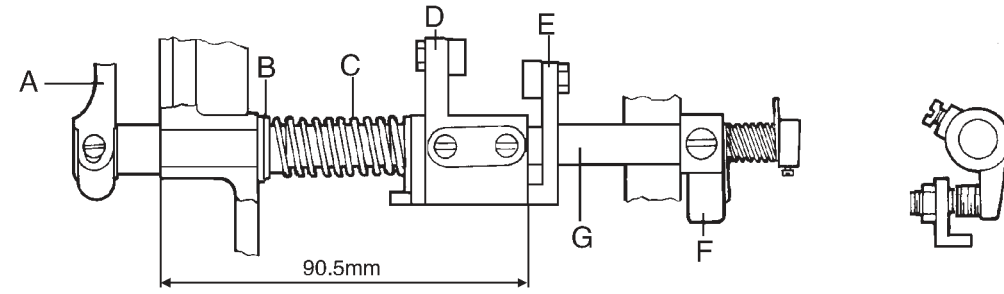

18.THE ELECTROMAGNET CORE STROKE

- (1)The standard stroke of the electromagnet core is 6mm.
- (2)The stroke can be adjusted with Positioning screw (A).

- B—thread cutting electromagnet holder
- C—thread cutting cam crank 2
- D—driving bar
- E—thread cutting electromagnet

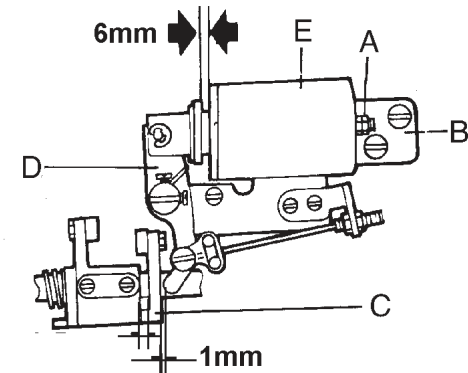

19.INSTALLING THREAD CUTTING CAM

- (1)Align No.2 Positioning Mark (A) on the balance wheel with Positioning Mark (B) on the machine arm.

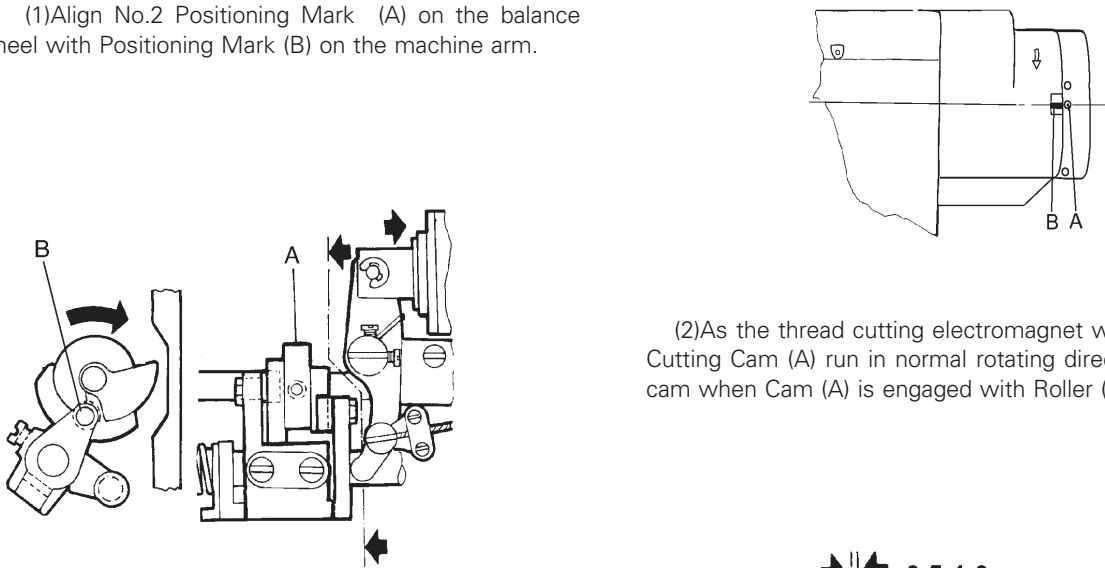

- (2)As the thread cutting electromagnet works, Thread Cutting Cam (A) run in normal rotating direction. Fix the cam when Cam (A) is engaged with Roller (B).

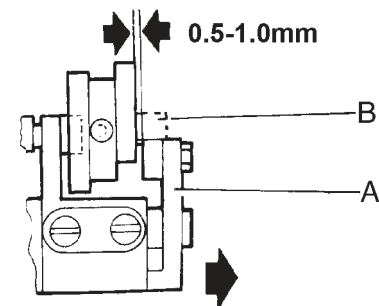

- (3)Stop the operation of the electromagnet, reset Cam Driving Crank (A), Cam (B) is separated from the engagement with the roller,the standard clearance is 0.5-1.0mm.

NOTE:

- 1.The figure shows the standard position of Cam Driving Crank (D) before operation.

- A—hook shaft B—roller C—cutter driving shaft

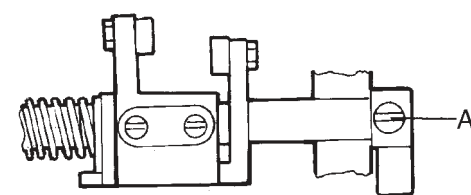
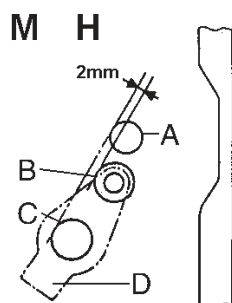

- 2.It may change the positions mentioned above to remove the stopper, then adjust with Screw (A), and readjust the above .

20.ADJUSTING KNIFE CUTTING ENGAGEMENT

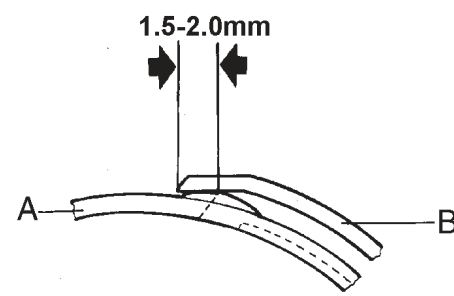

- ①When the electromagnet works, turn the machine, the movable knife (A) follows the motion of the thread cutting cam. The maximum degree of cutting engagement is 1.5-2.0mm (B—the fixed knife)
- ②Adjust the cutter driving crank if necessary.

21.ADJUSTING CUTTING PRESSURE

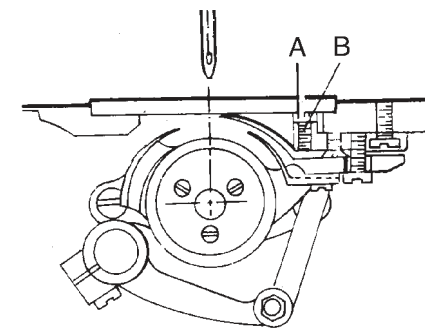

- (1)When cutting thick thread, increase the cutting force.
- (2)For adjusting cutting force, loosen Set Nut (A),and adjust Screw (B).

22.ADJUSTING NEEDLE THREAD TENSION

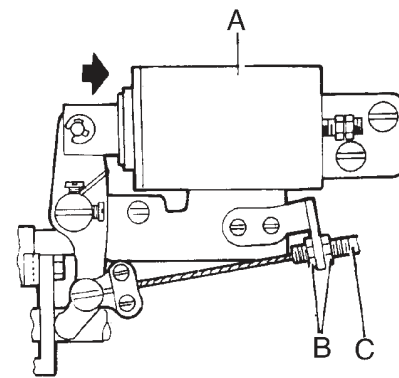

- There should be a clearance of 1mm between the two discs while the thread cutting electromagnet (A) is working.
- For adjustment, loosen Nut (B),and move soft thread (C).

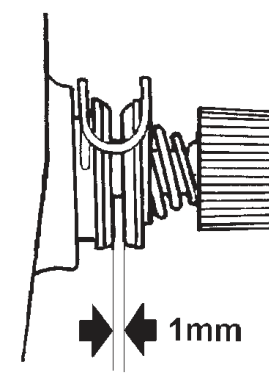

- Note: If the clearance is too small, the thread end left after cutting is too short and may easily go away from the needle eye; otherwise the tension is poor and affect the needle thread tension.

23.THREAD END REMAINS ADJUSTMENT

- To get the needle thread end remains properly, adjust Nut (A).
- Turn rightward: get shorter
 - Turn leftward: get longer

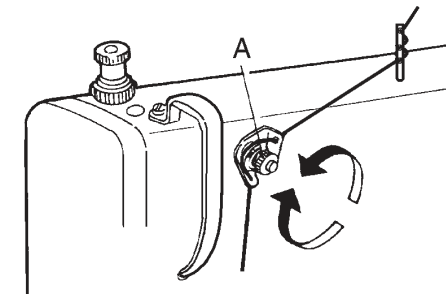

24.INSTALLING REVERSE STITCH ELECTROMAGNET

- Adjust the position of Electromagnet (A) properly to guarantee the flexible connection of the magnet with the link lever and the convenient operation of Reverse Stitch Bar (B), then set with a screw.

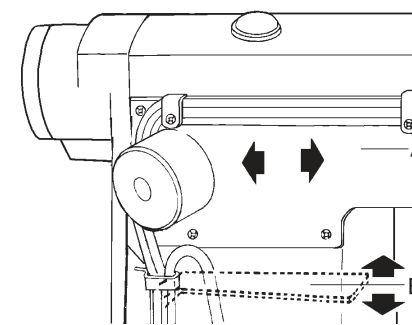

25.REVERSE STITCH SWITCH

- The figure shows the normal state.It can perform reverse sewing to switch on.If move the switch to the dotted line shown in the figure,and switch on,the reverses sewing can not be performed.

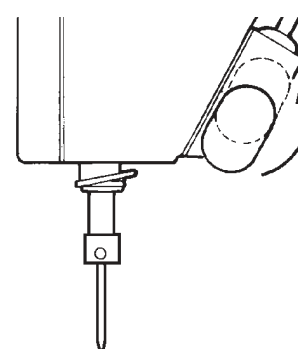

26.HOOK. BOBBIN CASE AND BOBBIN

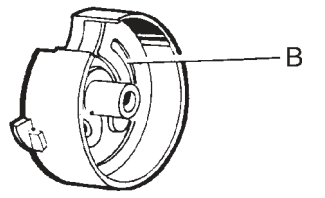
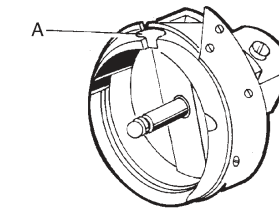

- 1.There is a thread groove (A) in the special hook for thread cutting sewing machine.

- 2.The bobbin case used in the machine should be with a spring (B) in its bottom, which prevents the bobbin from running without loading.

27.PERIODICAL CLEANING

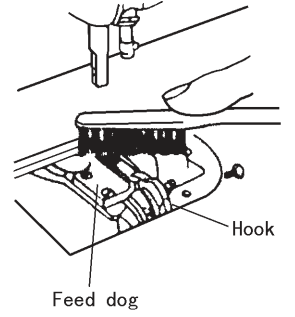
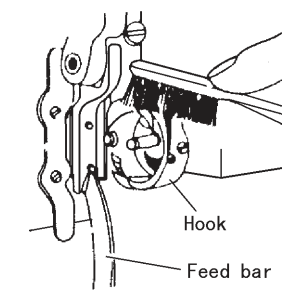

- 1)Cleaning feed dog
Remove the throat plate and clear off the dust and lint between feed dog tooth slots.
- 2)Cleaning rotating hook
Swing out the machine head and clean the hook.Wipe the bobbin case with soft cloth.
- 3)Cleaning oil pump screen
Swing out the machine head and clear off the dust and dirt on oil pump screen.

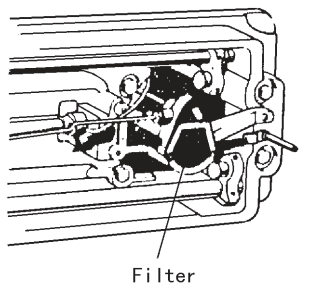

6717MD2 machine's main technical date

Application	Common materials
Sewing speed	4500 spm
Max. Stitch length	4mm
knee controlled Presser foot lifting	6-11mm
Rotating shuttle	Standard automatic oiling
Needle	DBx1 11#-#16
Trimedge width(mm)	Normal 3.2(mm) special 2.4 4.0 4.8 6.4 7.9 9.5

6717MD

- 1.Thread trimmer
- 2.Thread trimmer+Quick reverse (Automatic footlifter is optional)

XI'AN TYPICAL INDUSTRIES CO.,LTD.

Add: No.335 Taibai South Road,
Xi'an,P.R.China-710068
Tel :+86-29-88279091 88279150

Fax :+86-29-88249715 88245215
E-mail:typical@chinatypical.com
Http:www.chinatypical.com

TYPICAL



GC6717MD2 DIRECT DRIVE LOCKSTITCH SEWING MACHINE WITH THREAD TRIMMER AND EDGE CUTTER

PARTS CATALOGUE

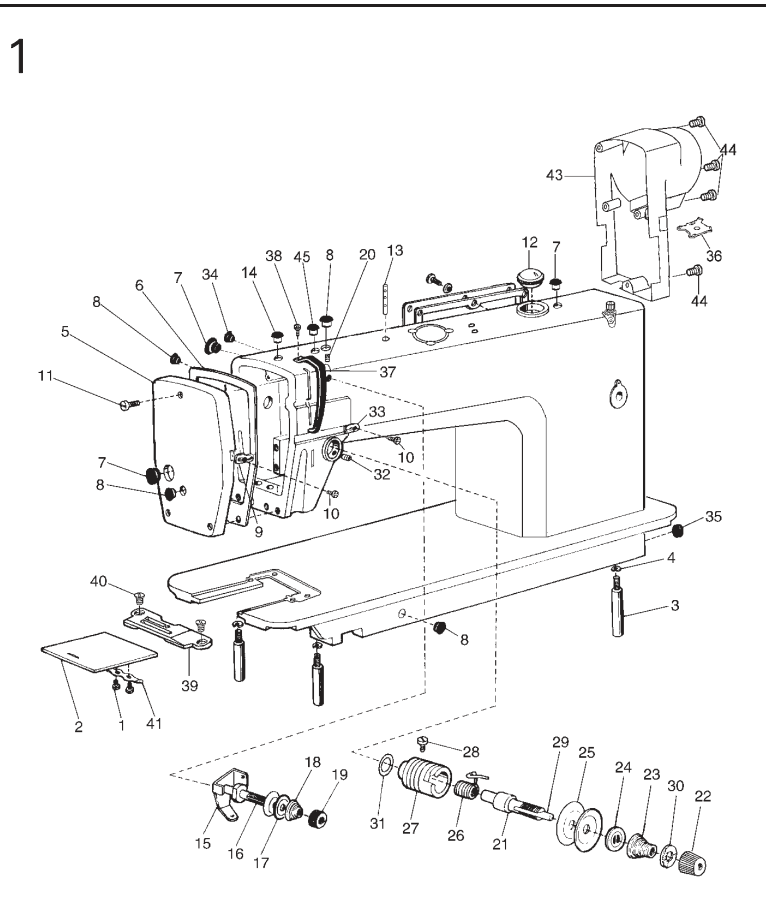

1.ARM AND BED MECHANISM

No.	Ref.No.	Description	Qt.
1	022170003	Screw	2
2	022170001	Slide plate	1
3	048100005	Leg	3
4	S150601004	Spring washer	3
5	258100001	Face plate	1
6	258100002	Face plate gasket	1
7	022130003--V	Rubber plug(Φ 19)	3
8	022130004--V	Rubber plug(Φ 11.8)	4
9	022130005	Thread guide on face plate	1
10	022130006	Screw	2
11	022100004	Screw	1
12	022180001--V	Oil check window	1
13	108200009	Thread guide pole	1
14	022200011--V	Rubber plug(Φ 8.8)	1
15	036240001	Pretension thread guide	1
16	036240002	Screw	1
17	022150003	Thread tension disc	2
18	036240003	Tension spring for pretension	1
19	036240004	Nut	1
20	124100006	Screw	1
21	022160001	Thread tension stud	1
22	124130001--W	Thread tension nut	1
23	124130002--d	Thread tension spring	1
24	022160004	Thread tension releasing disc	1
25	022160005	Thread tension disc	2
26	022160006	Thread take-up spring	1
27	022160007	Thread tension regulator bushing	1
28	022160008	Screw	1
29	238100004	Thread tension releasing pin	1
30	022160010	Stop disc	1
31	022160011	O-type ring	1
32	022100013	Set screw	1
33	022100014	Thread guide	1
34	022100015--V	Rubber plug(Φ 8.8)	4
35	022100016--V	Rubber plug(Φ 27)	1
36	236170002	All purpose screwdriver	1
37	BXF9768001	Thread take-up lever guard	1
38	022200004	Screw	1
39	029100003	Needle plate	1
40	022100020	Screw	2
41	022170002	Slide plate spring	1
43	238100003	Motor cover	1
44	S150216033	Screw M5X25	5
45	022100017--V	Rubber plug(Φ 5.7)	1

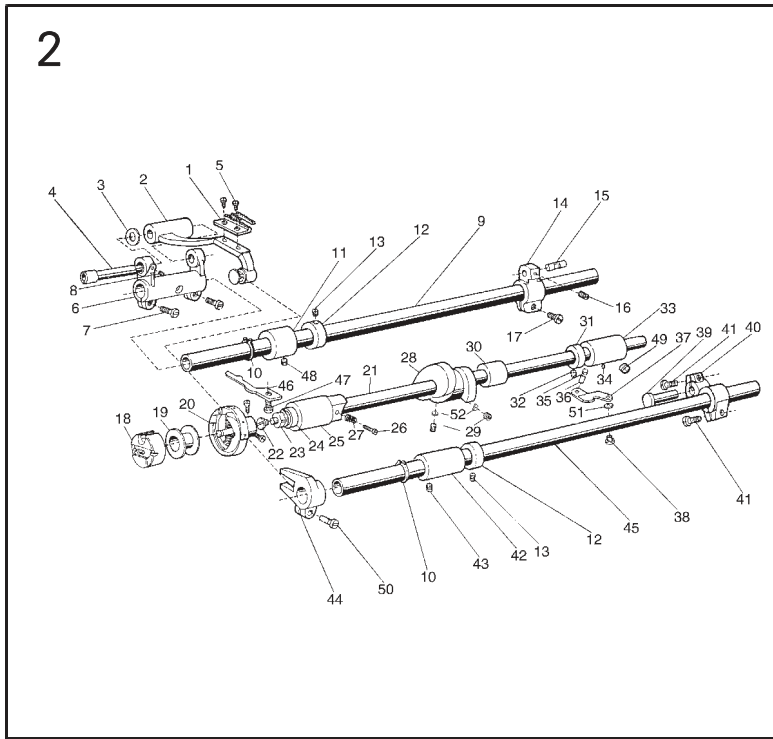

2.FEEDING AND FEED LIFTING AND ROTATING HOOK MECHANISM

No.	Ref.No.	Description	Qt.
1	029600001	Feed dog	1
2	036411000	Feed bar	1
3	022610006	Washer	1
4	036410002	Shaft for feed bar	1
5	022610004	Screw	2
6	022611001	Feed rock shaft crank	1
7	022612001	Screw	2
8	022200019	Screw	1
9	124600002	Feed rock shaft	1
10	S150617006	C-type stop ring 15	2
11	022600004	Bushing for feed rock shaft	1
12	022620001	Collar for feed rock shaft	2
13	022320002	Screw	4
14	036400003	Feed rock shaft crank(right)	1
15	036400204	Pin	1
16	036550005	Screw	1
17	022640003	Screw	1
18	054A00004	Bobbin case complete	1
19	036400006	Bobbin	1
20	022471000	Rotating hook complete	1
21	036440001	Hook shaft	1
22	022411001	Filter screw	1
23	022411002	Filter	1
24	036470001	Oil seal	1
25	036400010	Hook shaft bushing(left)	1
26	022400005	Oil adjusting screw	1
27	022400006	Coil spring	1
31	022420001	Collar for hook shaft	1
32	022200009	Screw	2
33	036460001	Hook shaft bushing(right)	1
34	022430002	Oil pipe for hook shaft bushing	1
35	036400015	Plunger	1
36	036400016	Plunger spring	1
37	022400010	Guide plate	1
38	022820001	Screw	1
39	022600007	Hinge pin	1
40	036400017	Feed lifting rock shaft crank(R)	1
41	022600016	Screw	2
42	022600012	Bushing for feed lifting shaft(L)	1
43	022200002	Screw	1
44	036484001	Feed lifting shaft crank	1
45	124600003	Feed lifting rock shaft	1
46	022400013	Hook positioner	1
47	022400015	Screw	1
48	022200009	Screw	1
49	022200002	Screw	1
50	022640003	Screw	1
51	S150601004	Washer	1
52	165400001	Washer	2

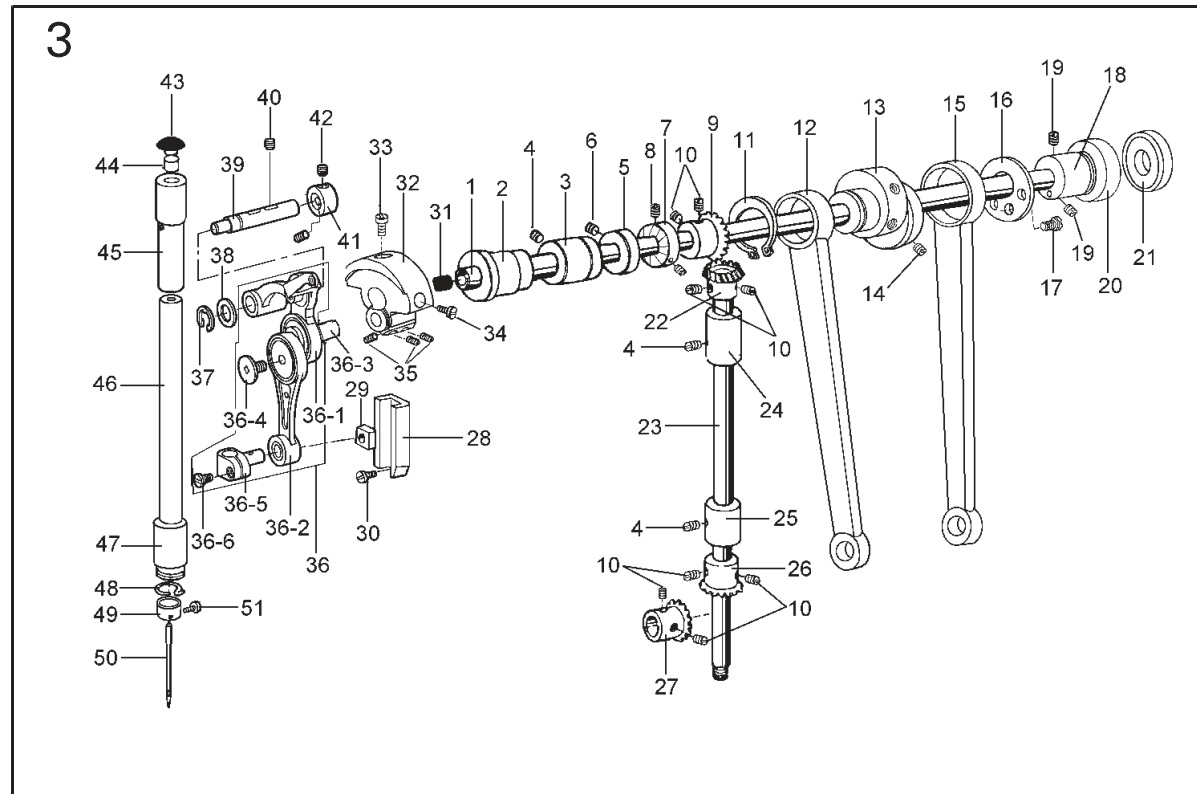

3.ARM SHAFT AND VERTICAL SHAFT THREAD TAKE-UP MECHANISM

No.	Ref.No.	Description	Qt.
1	258200001	Arm shaft	1
2	022320003	Arm shaft bushing(left)	1
3	022320004	Arm shaft bushing(middle)	1
4	022200002	Screw	3
5	022320001	Collar for arm shaft	1
6	022320002	Screw	2
7	207302001	Friction wheel	1
8	S150212006	Screw M5 x 6	2
9	Z0A180891	Bevel gear for arm shaft	1
10	022220003	Set screw	8
11	022342001	Spacer	1
12	022343001	Crank rod for lifting rock shaft	1
13	036340001	Eccentric wheel	1
14	022200002	Screw	2
15	036550002	Lever feed connecting rod	1
16	036300004	Spacer	1
17	165330001	Screw	3
18	257200002	Bearing	1
19	BX87459009	Screw M6 x 6	2
20	S150801006	Bearing	1
21	238200004	oil seal	1
22	Z0A180892	Bevel gear (upper)	1
23	022350001	Vertical shaft	1
24	022300011	Vertical shaft bushing (upper)	1
25	022300012	Vertical shaft bushing (lower)	1
26	Z0A180885	Bevel gear lower)	1
27	Z0A180886	Bevel gear for hook shaft	1
28	022200018	Guide rail for slide block	1
29	022200020	Slide block	1
30	022200019	Set screw	2
31	022310002	Rubber plug(Φ 7.4x10)	1
32	029200001	Needle bar crank	1
33	022200007	Set screw	1
34	022200006	Screw	1
35	BX87459009	Screw M6 x 6	3
36	230221100	The thread take-up assembly	1
36-1	BXF9970009	Choose line pole small components	1
36-2	BXF8914009	Needle bar connecting rod assembly	1
36-3	230100016	Thread take-up crank	1
36-4	BXF8688009	Screw SM3.57-40 x 6	1
36-5	BX85863009	Needle rod joints	1
36-6	B960006009	Screw SM3.57-40 x 7	1
37	B062040768	Spacer E6	1
38	BXF8949009	Grommet	1
39	BXF9986009	Thread take-up lever hinge axis	1
40	B098049074	Screw M6 x 10	1
41	BXF9985009	Shrink-ring	1
42	B098600674	Screw M4 x 4	2
43	022200011--v	Rubber plug	1
44	022200010	Felt plug	1
45	153200004	Needle bar bushing(upper)	1
46	029200002	Needle bar	1
47	153200005	Needle bar bushing(lower)	1
48	022230002	Thread guide	1
49	029200003	Thread guide for needle bar	1
50	S150901001	Needle	1
51	022200017	Screw	1

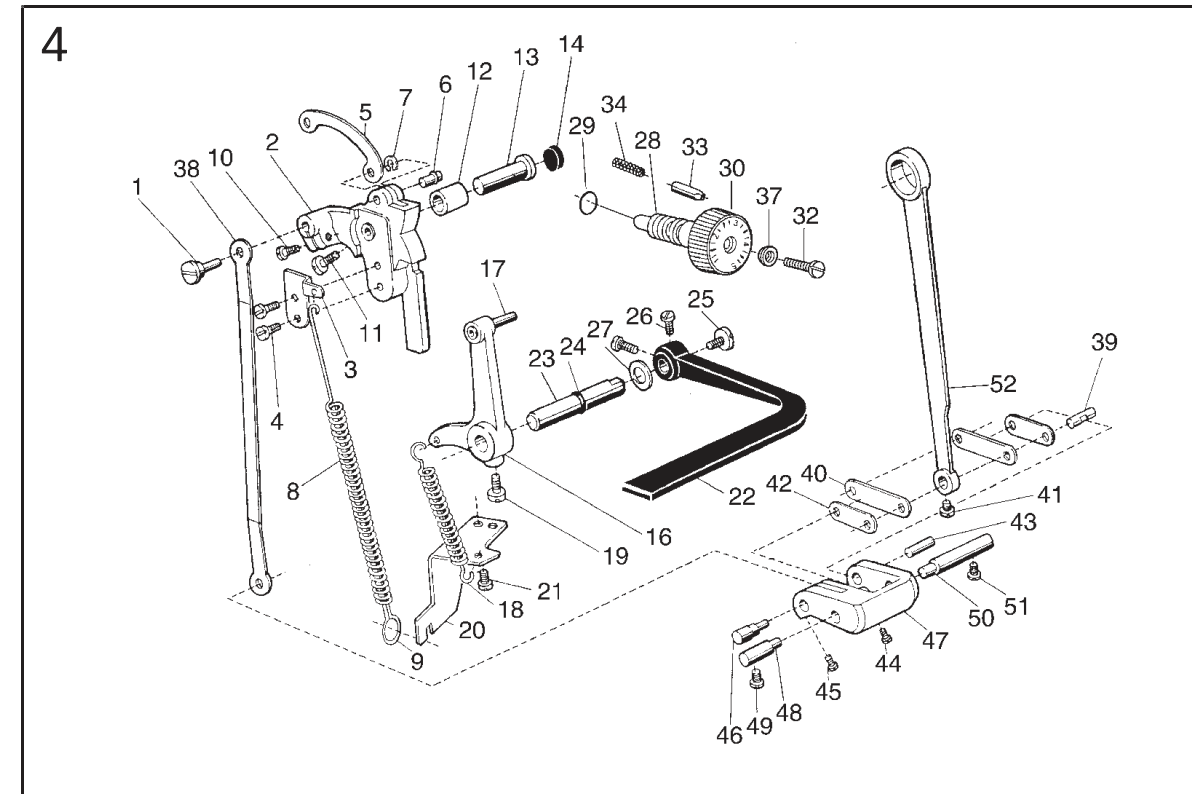
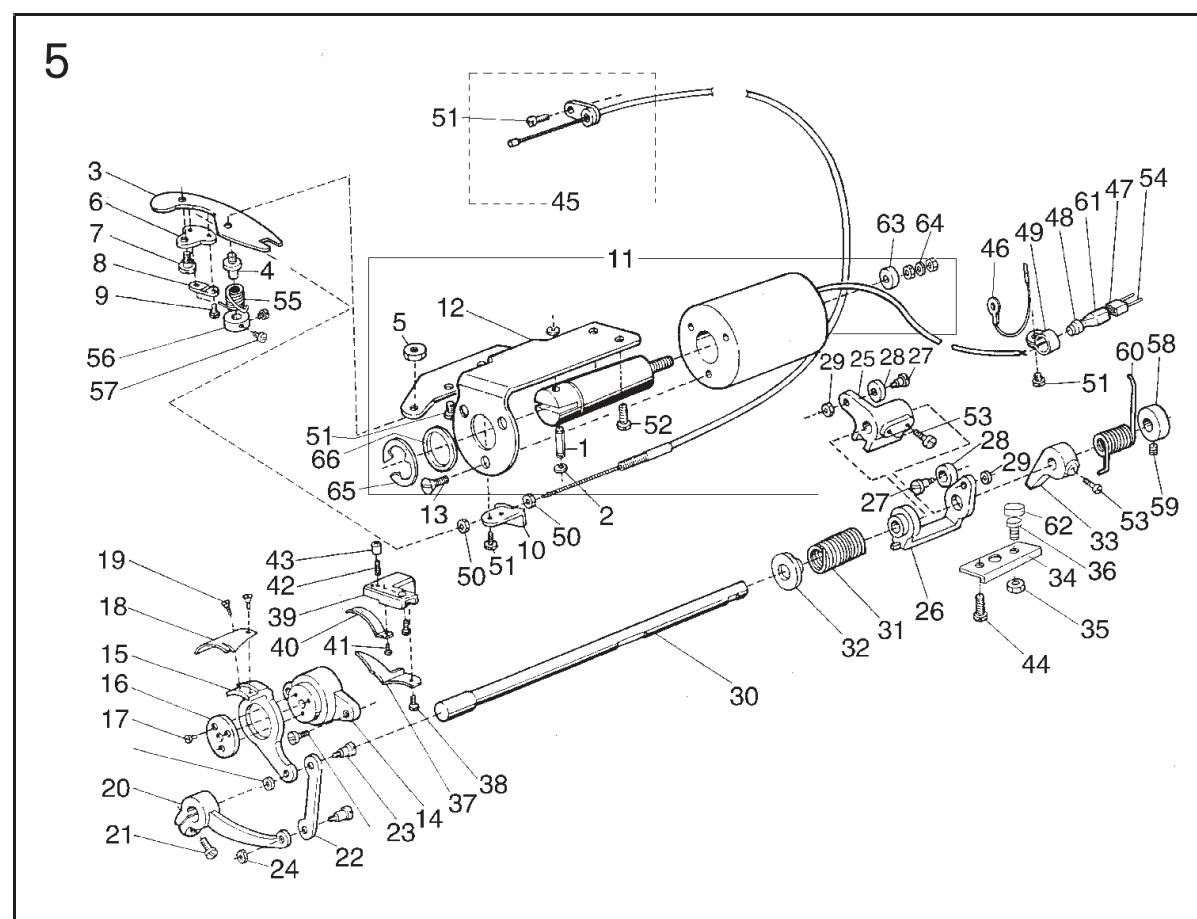

4.NEEDLE FEED MECHANISM

No.	Ref.No.	Description	Qt.
1	036500001	Connecting stud	1
2	036510001	Feed regulator	1
3	036510002	Spring retainer	1
4	022200019	Screw	2
5	036510003	Link	1
6	036510004	Feed regulator shaft	1
7	S150620004	Retaining ring E4	1
8	036510005	Feed regulator spring	1
9	036510006	Spring holder	1
10	022640003	Screw	1
11	022540004	Screw	1
12	238300001	Bushing for feed regulator	1
13	022500004	Pin shaft	1
14	238300002	Rubber plug(Φ 16)	1
16	036520001	Back tacking crank	1
17	036520002	Back tacking lever shaft	1
18	036520003	Lever spring	1
19	022500013	Set screw	1
20	036500005	Bracket for spring	1
21	022820001	Set screw	1
22	124500004--W	Back tacking lever	1
23	0365310001	Back tacking lever shaft	1
24	S150651007	O-ring 6.3 x 1.8G	1
25	022540003	Screw	1
26	022540004	Screw	2
27	022500011	O-ring	1
28	238300003	Feed regulator screw	1
29	124510003	Screw	1
30	238300005	Knob	1
32	238300004	Screw	1
33	238300004	Stopper pin	1
34	022500009	Spring for stopper pin	1
37	036540004--d	Bush	1
38	036550003	Feed regulator link	1
39	036400104	Sink shaft	1
40	036558002	Feed rock arm link	2
41	036550005	Screw	1
42	036558001	Feed rock link	2
43	036550006	Pin	1
44	036550007	Screw	1
45	036550008	Screw	1
46	036550009	Lever link eccentric shaft	1
47	036550010	Lever regulator	1
48	036580002	Pin(left)	1
49	022640003	Screw	1
50	036580001	Pin(right)	1
51	022640003	Screw	1
52	036550002	Lever feed connecting rod	1

5.KNIFE ACTUATING MECHANISM

No.	Ref.No.	Description	Qt.
1	036800009	Pin	1
2	S150620004	Spacer	2
3	036710001	Flexible driving lever	1
4	036710002	Screw	1
5	022910010	Nut	1
6	036710003	Bracket for flexible bracket	1
7	036710004	Screw	1
8	036710005	Plate	1
9	036710006	Screw	2
10	036710007	Holder for flexible wire	1
11	036711000-V	trimmer	1
12	036712	Solenoid mounting bracket	1
13	S150203006	Screw(M4X6)	3
14	036721001	Knife holding saddle	1
15	036721002	knife base(left)	1
16	038721003	Washer	1
17	036721004	Screw	3
18	038720002	Blade(left)	1
19	036720003	Screw	2
20	036720004	Vibrating shaft crank	1
22	036720005	Feed link	1
23	036720006	Screw	2
24	036720007	Nut	2
25	036730001	Cam follower crank(1)	1
26	036730002	Cam follower crank(2)	1
27	036730003	Roller stud	2
28	036730004	Roller stud	2
29	036730005	Nut	2
30	036700004	Knife driving shaft	1
31	036700005	Spring	1
32	036700006	Bushing	1
33	165720004	Stopper	1
34	165720001	Stopper plate	1
35	S150503005	Nut M6	1
36	165720002	Screw	1
37	036750001	Thread guide	1
38	022130006	Screw	1
39	036750002	Bracket for fixed blade	1
40	027A00011	Fixed knife	1
41	036750004	Screw	1
42	036750005	Screw	1
43	036750006	Nut	1
44	036800002	Screw	2
45	03676	Flexible wire asm	1
46	036770000	Earth wire asm	1
47	108500003	Plug	1
48	036700013--V	Rubber ring	1
49	036700014	Wire clamp	1
50	S120501005	Nut M5	2
51	022200019	Screw	8
52	036800002	Screw	2
53	165730008	Screw	3
54	036911002	Pin	2
55	036710009	Spring	1
56	036710010	Collar	1
57	036550008	Screw	2
58	036780001	Collar	1
59	022320002	Screw	1
60	036700016	Spring	1
61	108400005--V	Guard for plug	1
62	165720003	Rubber washer	1
63	165710001	Rubber washer	1
64	S150632004	Retaining ring 5	1
65	S150620012	Spacer 12	1
66	036711001	Washer	1

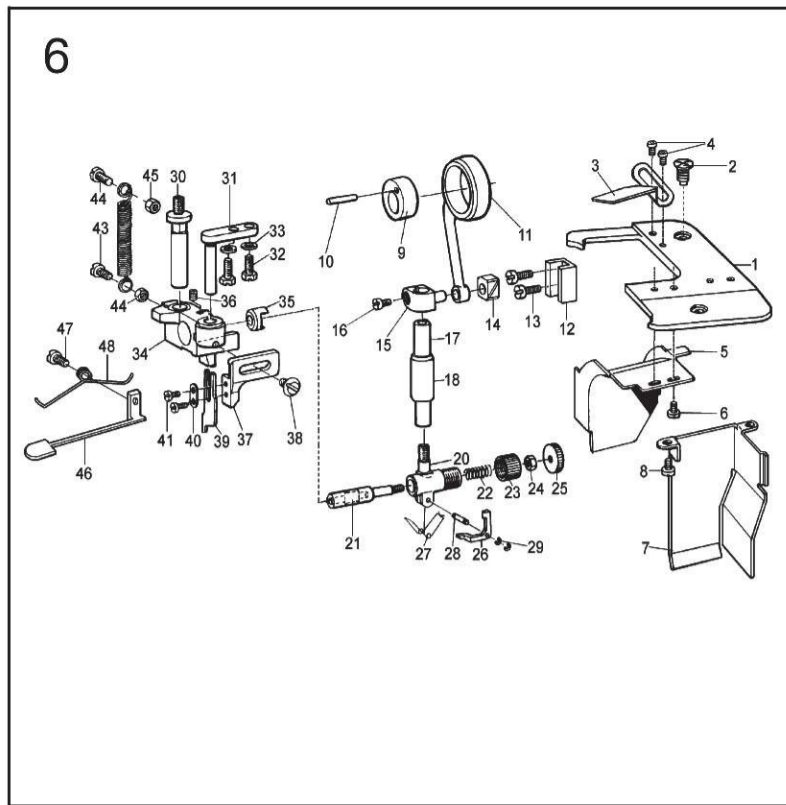

6.CUTTER MECHANISM

No.	Ref.No.	Description	Qt.
1	029800001	Throat plate	1
2	022100020	Screw	2
3	029800002	Waste material guide	1
4	022830004	Screw	2
5	029800101	Waste material chute	1
6	028300034	Screw	2
7	029800104	Waste material guard	1
8	022210009	Screw	2
9	029800006	Knife driving eccentric cam	1
10	S150403005	Knife driving eccentric cam pin	1
11	029800007	Knife driving rod	1
12	029800008	Slide block guide	1
13	022200019	Screw	2
14	022200020	Crank slide block	1
15	029800009	Knife driving stud connection asm	1
16	036550008	Screw	1
17	029800010	Knife driving stud	1
18	029800011	Bushing	1
20	029800012	Knife driving rod clutch retainer	1
21	029800013	Knife driving rod clutch pin	1
22	029800014	Spring	1
23	029800015	Cap	1
24	028100035	Nut	1
25	029800016	Knob	1
26	029800017	Knife release lever	1
27	029800018	Spring	1
28	029800019	Pin	1
29	S150620008	Snap ring	2
30	029800020	Knife driving block stud	1
31	029800021	Guide stud for knife driving block	1
32	S150209033	Screw	2
33	217100024	Washer	2
34	029801000	Knife driving block asm	1
35	029801004	Clutch pin bushing	1
36	028700004	Screw	1
37	029800022	Knife holder	1
38	029800023	Screw	1
39	029800024	Knife	1
40	029800025	Washer	1
41	036710006	Screw	2
42	029800026	Tension spring	1
43	022100006	Screw	1
44	022510004	Screw	1
45	022900010	Nut	1
46	029700004	Wrench for knife driving blk	1
47	029700005	Screw	1
48	029700006	Spring	1

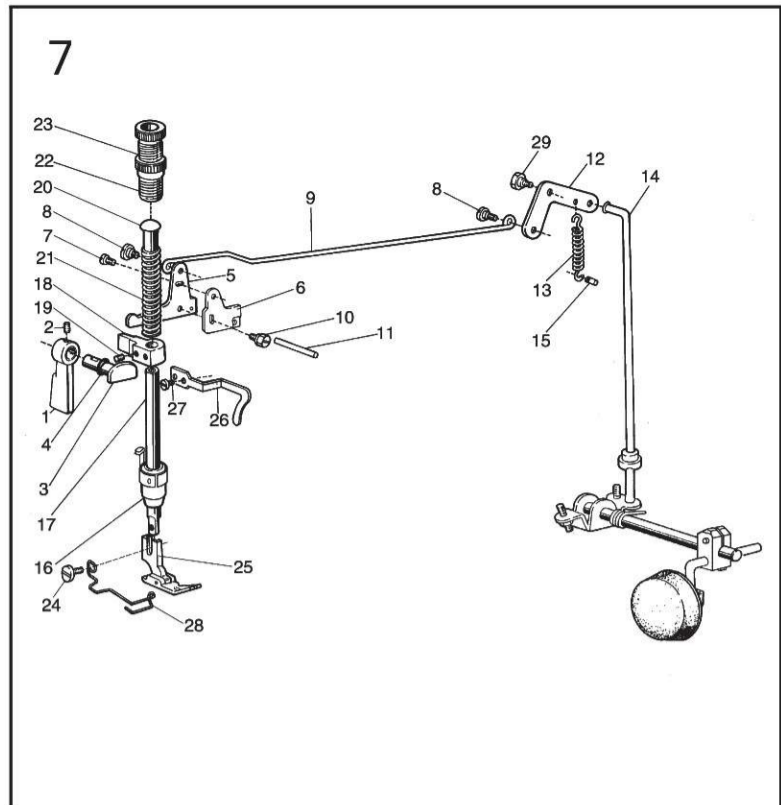

7.PRESSER FOOT MECHANISM

No.	Ref.No.	Description	Qt.
1	022710001--W	Presser bar lifter	1
2	B0406000294	Screw	1
3	036620001	Presser bar lifting cam	1
4	S150651010	Oil seal(4.5 x 1.8G)	1
5	022722001	Knee lifter lever (left)	1
6	022722001	Tension relasing cam	1
7	022723001	Screw	1
8	022720002	Screw	2
9	022720003	Knee lifter rod	1
10	022700005	Screw	1
11	029500101	Thread releasing pin	1
12	022730001	Knee lifter lever (right)	1
13	022730002	Coil spring	1
14	022730003	Knee lifter connecting rod	1
15	022700008	Pin for spring	1
16	022700009	Bushing for presser bar	1
17	029700001	Presser bar	1
18	022740001	Presser bar guide bracket	1
19	022100013	Screw	1
20	022700012	Presser bar spring guide	1
21	022700013	Presser bar spring	1
22	022750001--W	Screw	1
23	022750002--W	Lock nut	1
24	022700015	Screw	1
25	029701000	Presser foot asm	1
26	022700016	Thread guide	1
27	022200004	Screw	1
28	057700002	Presser foot spring	1
29	022730004	Screw	1

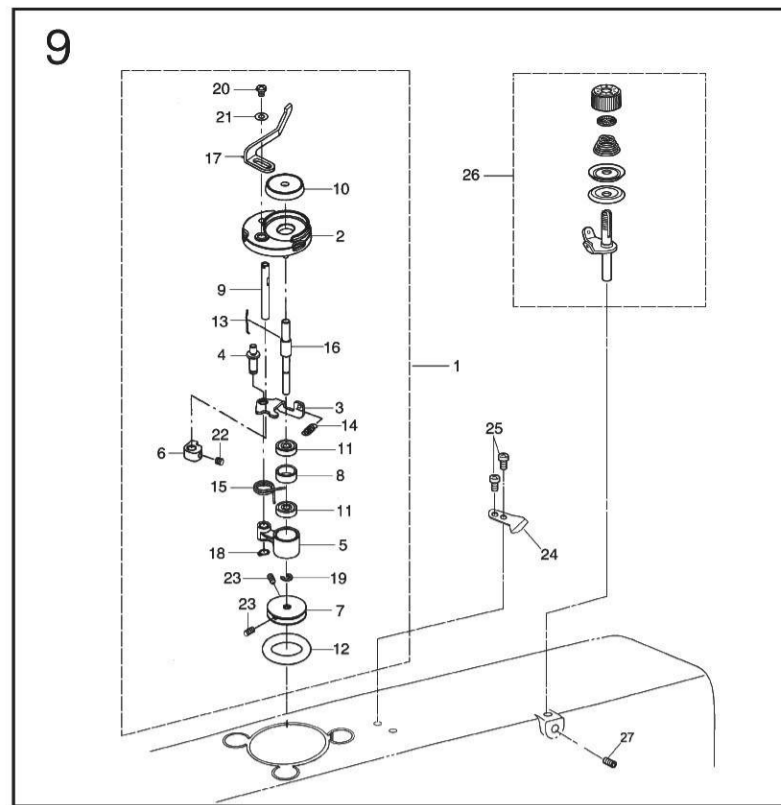
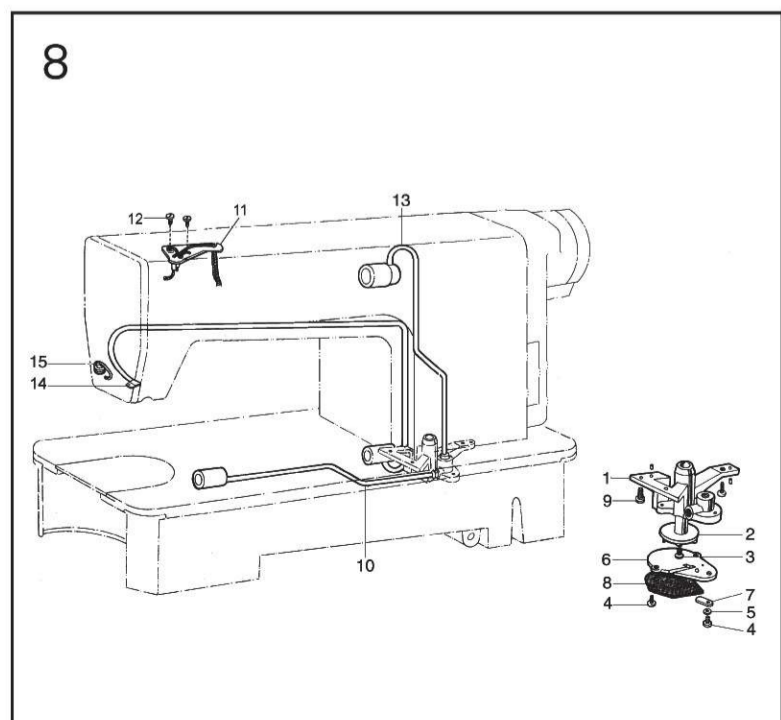

9.BOBBIN WINDER MECHANISM

No.	Ref.No.	Description	Qt.
1	207107000--W	Bobbin winder complete	1
2	207107004	Bobbin winder support	1
3	207107014	Bobbin winder lever	1
4	207107012	Bobbin winder lever shaft	1
5	207107006	Bobbin winder crank	1
6	207107011	Bobbin winder cam	1
7	207107008	Bobbin winder wheel	1
8	207107007	Bear bushing	1
9	207107010	Bobbin winder cam shaft	1
10	207107003	Bobbin support	1
11	S150866067	Bear 625ZZHR	2
12	207107009	Rubber ring	1
13	207107002	Spring	1
14	207107005	Spring	1
15	207107013	Spring	1
16	207107001	Bobbin winder shaft	1
17	207107015	Wrench	1
18	S150617001	Retaining ting C6	1
19	B062060768	Retaining ting E4	1
20	S150237046	Screw M4x5	1
21	S150633007	Washer	1
22	S150212013	Screw M5x5	1
23	S150299012	Screw M4x6	2
24	001100009	Knife	1
25	022830004	Screw SM3.57	2
26	BXF9116009--W	Thread tension complete(S)	1
27	022200009	Screw	1

8.OIL PUMP MECHANISM

No.	Ref.No.	Description	Qt.
1	022800001	Oil pump	1
2	022800002	Oil pump impeller	1
3	022800003	Screw	1
4	022800004	Screw	3
5	S150601003	Springe washer 3	1
6	022800006	Oil pump fitting plate	1
7	022800007	Oil adjusting plate	1
8	02281	Oil pump screen asm	1
9	022800009	Screw	3
10	022820N	Oil pump for hook shaft	1
11	022831	Oil braid fitting plate	1
12	022700015	Screw	2
13	022840N	Oil pump for arm shaft	1
14	022800015	Oil return pipe	1
15	036A00002	Oil filter holder	1

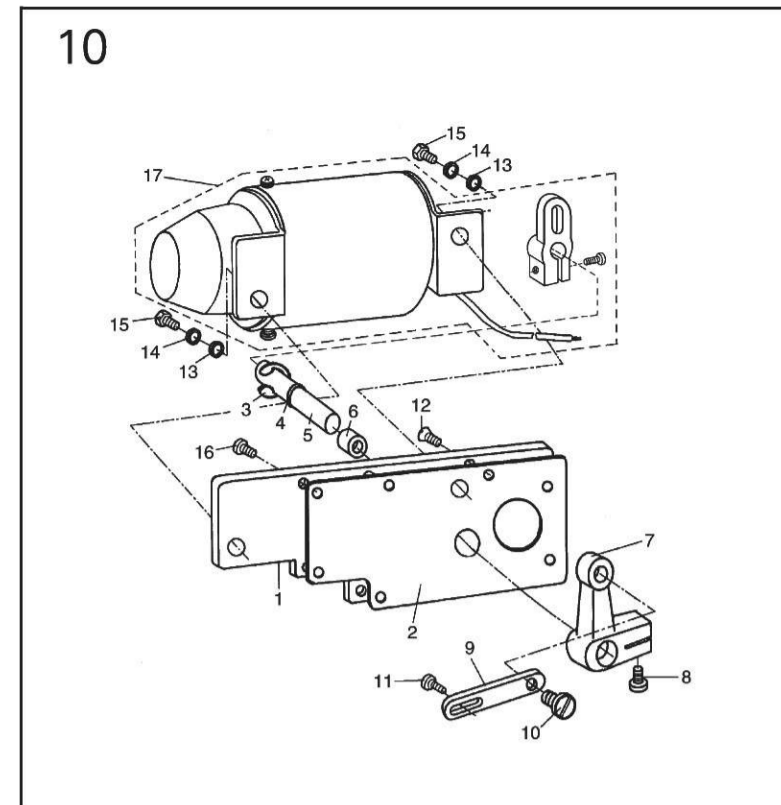

10.AUTOMATIC FOOT LIFTER MECHANISM

No.	Ref.No.	Description	Qt.
1	108C01000	Back plate	1
2	036850001	Washer	1
3	S150620009	Spacer	1
4	S150607005	Washer	1
5	108C02004	Shaft	1
6	110280000	Oil seal	1
7	108C02002	Feed rock shaft crank	1
8	022612001	ScrewSM3/16" (4.76) x28/12	1
9	108C02001	rod	1
10	108C02003	Screw	1
11	108C00001	Screw	1
12	108C01003	ScrewSM11/64" (4.37) x40/9.4	1
13	S150610007	Washer	2
14	S150632003	Washer	2
15	S150258010	Screw M6x10	2
16	022640003	ScrewSM11/64" (4.37) x40/12	7
17	108C03000	Foot lifter solenoid	1

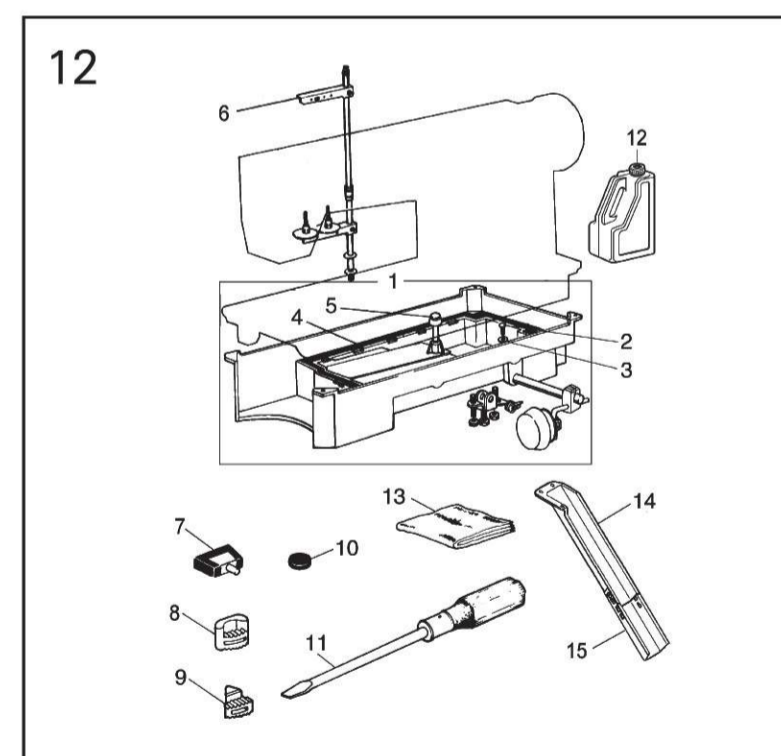

12.OIL RESERVOIR AND ACCESSORIES

No.	Ref.No.	Description	Qt.
1	029F00000	Oil reservoir asm	1
2	022910002	Screw	1
3	022910003	Washer	1
4	022910005	Washer	1
5	165F01001	Knee lifter lifting pin	1
6	006F00030--W	Thread spool asm	1
7	02299	Hinge with rubber cushion	2
8	022900009--V	Cushion(B)	2
9	022900010--V	Cushion(S)	2
10	W050103001	Magnet block	1
11	W060401018	Screw drive(long)	1
12	022900017	Oil tank	1
13	W060302036	Machine head cover	1
14	029F00002	Waste bucket (upper)	1
15	028800008	Waste bucket (lower)	1

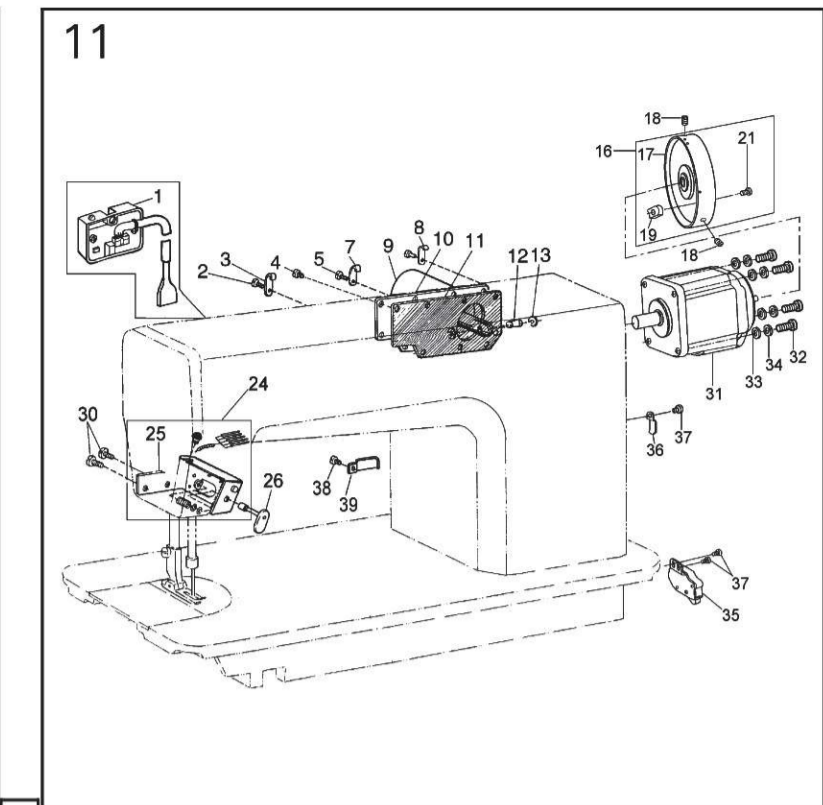

11.REVERSE SEWING AND DETECTOR MECHANISM

No.	Ref.No.	Description	Qt.
1	238100006	Detector componts	1
2	022200019	Screw	2
3	238C00008	Cord holder	1
4	022640003	Screw	6
5	022100006	Screw	2
7	238C00008	Cord holder	1
8	027A00010--d	Cord holder	1
9	238731000	Electric-magnet for reverse sewing	1
10	165820001--W	Side plate	1
11	036850001	Washer	1
12	036800009	Pin	1
13	S150620004	Spacer	2
16	238710000	Hand wheel asm	1
17	238710001	Hand wheel	1
18	S150215001	Screw M5x8	2
19	238710002	Magnet assembly	1
21	B040600294	Screw M4x8	1
24	036830000	Reserve sewing switch asm	1
25	029700100--W	Bracket of reserve sewing switch	1
26	036811	Button components	1
30	022200019	Screw	2
31	257E00001	Motor	1
32	B048509294	Screw M5x18	4
33	B084050974	Flat Washer S5	4
34	B082050864	Spring Washer	4
35	238720000	Safety switch asm	1
36	238700006	Cord holder	1
37	B048500294	Screw M5x8	3
38	022200019	Screw	4
39	BXF9716009	Cord holder U	1

OPTIONAL PARTS LIST

Edge cutting width	Pressure finger	Needle plate	Feed dog	The hopper
2.4mm(3/32)choose	029701000	029100002	029600001	029800101
3.2mm(1/8)		029100003		
4.0mm(5/32)choose	029702000	029100004		
4.8mm(3/16)choose		029100005		
6.4mm(1/4)choose	02276	029100006	029600002	029800102
7.9mm(5/16)choose		029100007		
9.5mm(3/8)choose		029100008		

XI'AN TYPICAL INDUSTRIES CO.,LTD.

Address: No.335 Taibai South Road, Xi'an,P.R.China-710068
 Tel :+86-29-88279091 88279150
 Fax :+86-29-88249715 88245215
 E-mail:typical@chinatypical.com
 Http:www.chinatypical.com